

THIS DRAWING IS UNPUBLISHED. RELEASED FOR PUBLICATION, 19 .
 © COPYRIGHT 19 BY AMP INCORPORATED. ALL RIGHTS RESERVED.

LOC	DIST	REVISIONS			
P	LTR	DESCRIPTION	DATE	DWN	APVD
AJ	16	G	REDWN AND REV PER EC 0220-0720-95	15FEB96	MEC FPM
		H	REVISED PER 0503-0155-96	12-9-96	JG FM

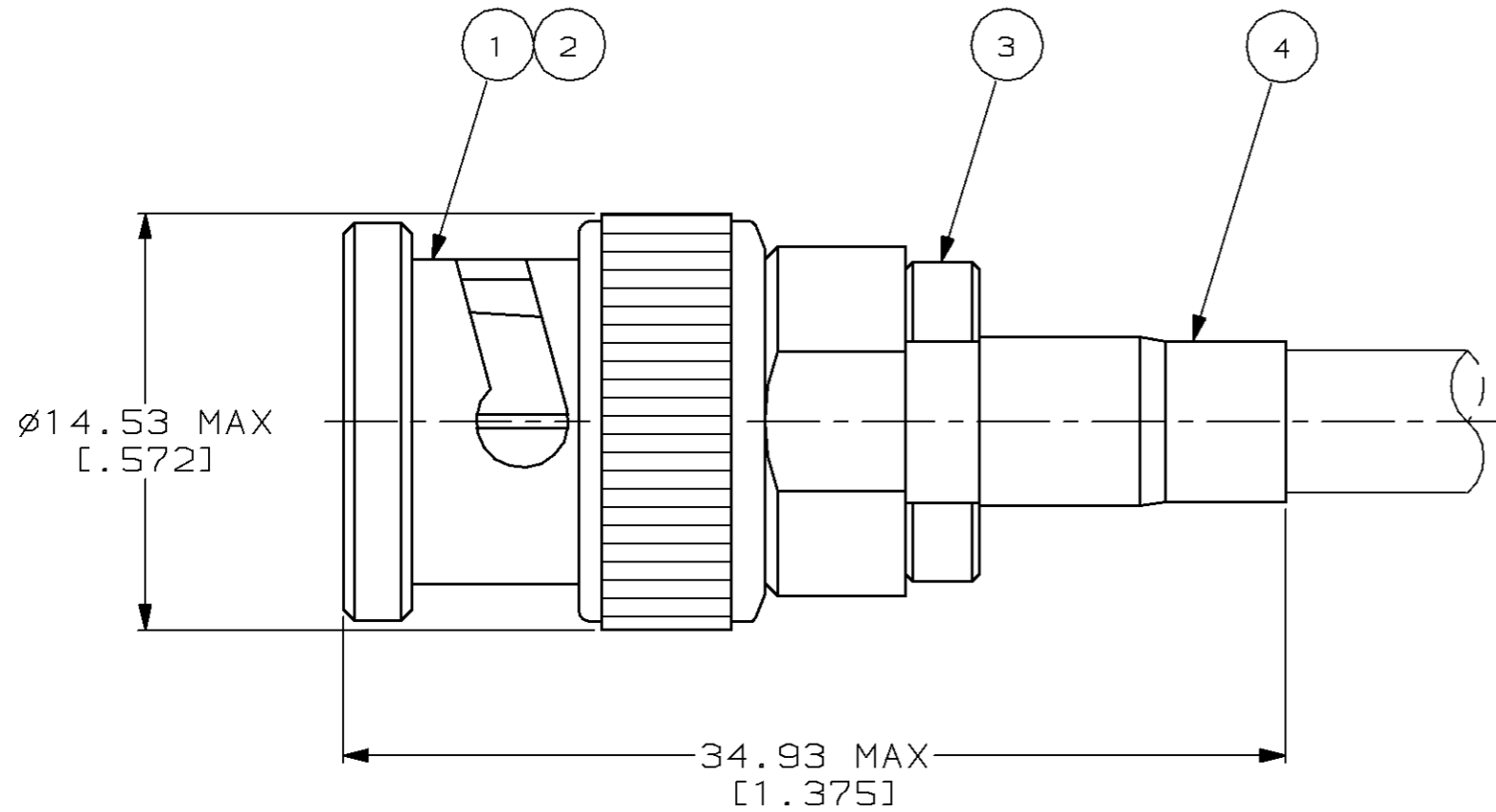

- 1. USE INSTRUCTION SHEET 1799-1
- 2. USE CRIMP TOOL 69140-1 WITH CABLE RG-58/U, 58A/U, 58B/U, 58C/U
- 3. USE CRIMP TOOL 69140-2 WITH CABLE RG-55/U, 55A/U, 55B/U AND 223/U

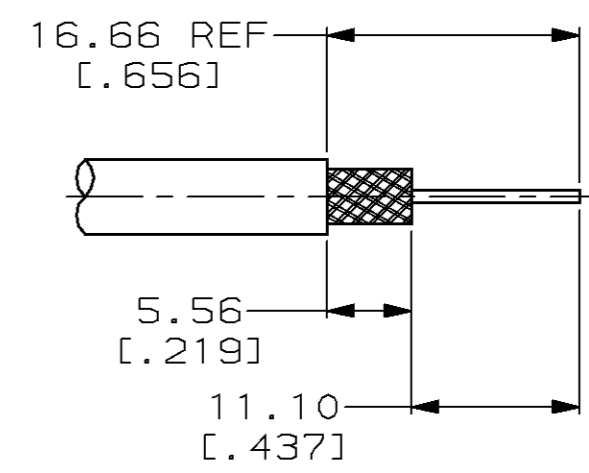

RECOMMENDED STRIP LENGTH
SCALE 2:1

OBSOLETE	-	-	-	-	7-329444-1
3	329099	50780-1	2-329106-1	329804	2-329444-2
2	328663	50780-1	2-329106-1	329804	2-329444-1
SUPERSEDED BY 2-329444-1					
4	FERRULE QTY=1	3	CRIMP END ASSEMBLY QTY=1	2	GASKET QTY=1
				1	PLUG ASSEMBLY QTY=1
					PART NUMBER

THIS DRAWING IS A CONTROLLED DOCUMENT.		DWN MICHAEL E. COWHER 06FEB96	AMP AMP Incorporated Harrisburg, PA 17105-3608
		CHK FRANK P. MORANA 15FEB96	
DIMENSIONS: mm [INCHES]		APVD FRANK P. MORANA 15FEB96	NAME
TOLERANCES UNLESS OTHERWISE SPECIFIED:		PRODUCT SPEC	PLUG, BNC
0 PLC ±-		APPLICATION SPEC	SIZE
1 PLC ±-		WEIGHT	CAGE CODE
2 PLC ±0.41 [0.016]			DRAWING NO
3 PLC ±-			A3 00779 C-329444
4 PLC ±-			SCALE
ANGLES ±-			4:1
MATERIAL -			SHEET
FINISH -			1 OF 1
		CUSTOMER DRAWING	REV
			H